

ACCU-SAMPLE™ (PATENT PENDING) AVIATION FUEL SAMPLING CONNECTION

In the past, Aviation Fuel sample connections requiring a shut-off valve were constructed from off-the-shelf parts configured into a kit. These kits included a separate probe, valve and Quick Disconnect, resulting in multiple connections and O-rings. The Coupling was assembled by pipe fittings with Teflon tape sealant. These kits were assembled by the customer, often requiring an extra labor cost seldom accounted for.

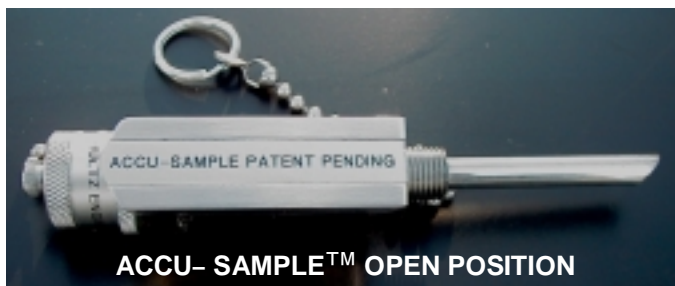

ASTM Aviation Fuel Particulate Contamination test method D 2276, A2.3 requires a sample point. Part 2.3.1 states ... **“Care should be taken in such cases to avoid trapping or general contamination”**... and 2.3.2. **“Sample Valve Connection...must have a minimum of internal recesses which could cause the hold up of contamination”**....

With this in mind, we developed the **ACCU-SAMPLE™** (Patent Pending) Quick disconnect with integral ball valve and probe. The **ACCU-SAMPLE™** surpasses currently existing designs by eliminating multiple connections and recesses where contaminate, particulate and/or sediment might be trapped.

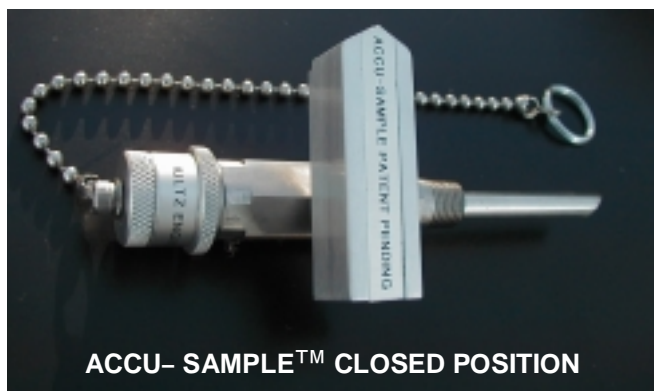

This ensures accurate sampling. The unibody design utilizes only one ¼ “ npt connection, resulting in three times less leak points than other designs. To further minimize internal recesses, internal threads exposed to fluid discharge path have been eliminated. Special handle design will not allow coupler to be engaged or disengaged while ball valve is in the “OPEN” position. Coupler ends are interchangeable with existing manufacturers actuators. Through advanced design the **ACCU-SAMPLE™** offers a better solution for your sampling connection needs.

ACCU-SAMPLE™ (PATENT PENDING) SAMPLING CONNECTION CUTAWAY

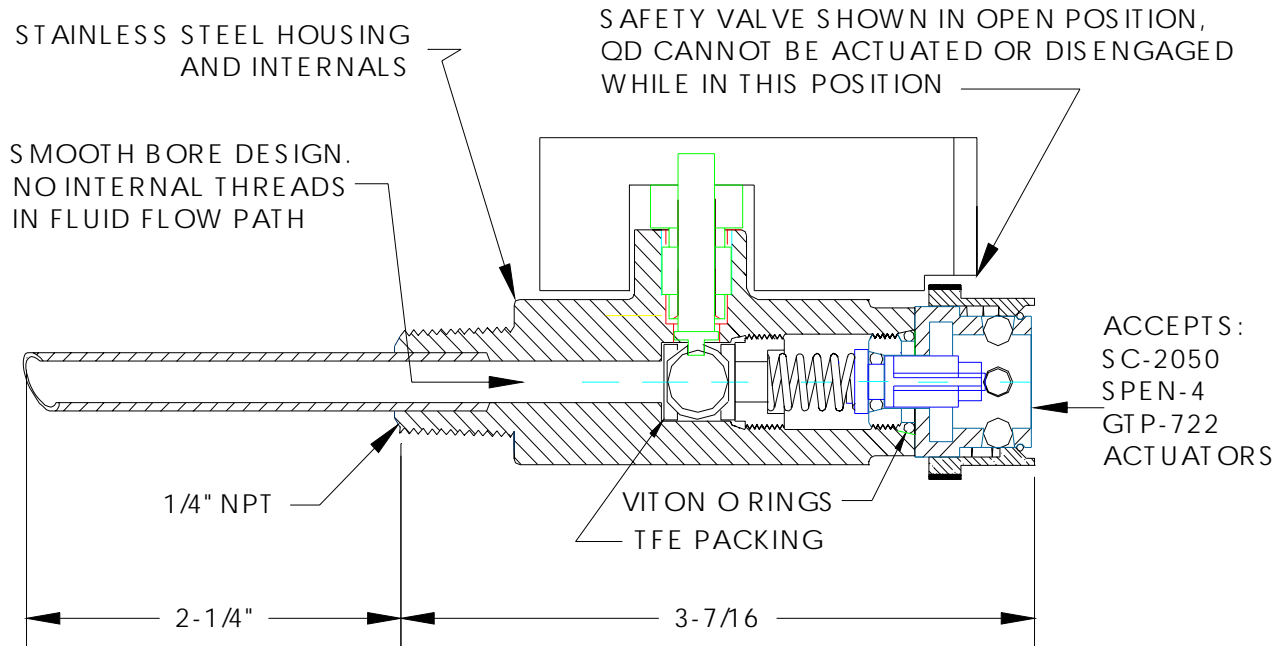

◆ Patent pending

- ◆ Made to conform to ASTM Specifications A2.3.1 & A2.3.2.
- ◆ Unibody coupler minimizes fittings & internal recesses
- ◆ Smooth Bore eliminates threads, which could trap sediment, thereby insuring accurate fuel samples.
- ◆ Fewer pipe fittings, O-rings and internal surface variations provide increased safety over previous offered designs.
- ◆ Safety Handle prevents coupler from being engaged or disengaged while valve is open preventing unnecessary fuel discharge.
- ◆ Stainless steel Unibody construction w/ Teflon seals and O-rings.
 - ◆ Fully rebuildable. Compact design.
 - ◆ 2-1/4" Probe Length, custom Lengths available.
- ◆ Quick disconnect coupling end features stainless steel internal components.